

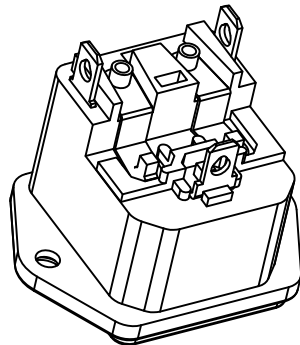

S-03F-11-D

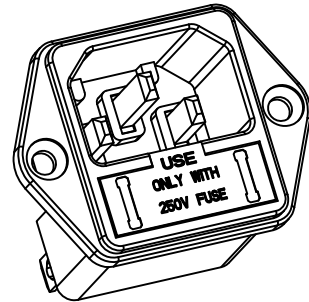
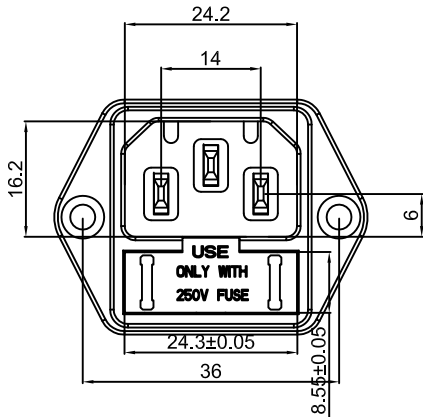

Rating: 6.3A 250V AC (UL CUL)
 6.3A 250V AC (VDE)
 10A 250V AC (CCC)

Insulation Resistance: DC 500V 100MΩ Min.
 Dielectric Strength: AC2000V 1 minute
 Fuse:Ø5.0x20mm

MATERIAL:
 Body:PBT
 Terminal:Brass,Silver or Tin plated

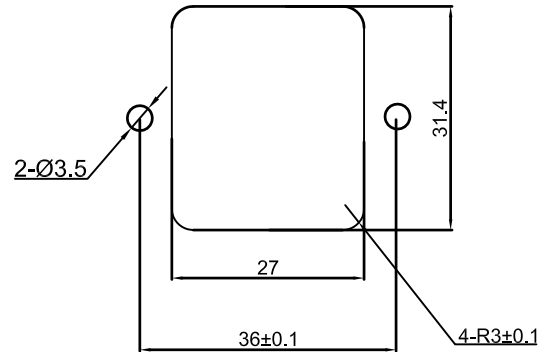
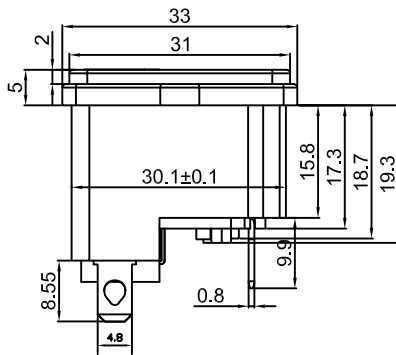
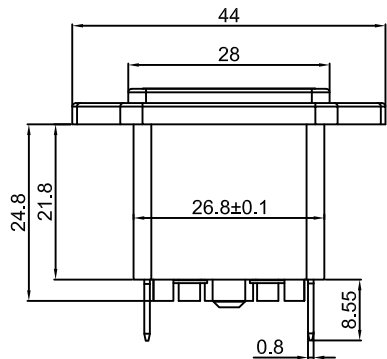

CUT-OUT

				公差 TOLERANCES		.X± 0.3	.XX± 0.15	角度 ANGLE ± 1°	单位 DIMENSION UNIT mm.	
A1	重新整理发行	2021.4.22	N/A	版本 VERSION	A1	比例尺 SCALE	NONE	日期 DATE	2021.4.22	
A0	New Issue	2013.03.14	N/A	核准		核对	NONE	绘图		
版本 VER.	变更说明 CHANGE DESCRIPTION	日期 DATE	ECN NO.	APPROVED BY		CHECKED BY		DRAWN BY		
									品名 TITLE	图号 DRAWING NO
									S-03F-11-D	S-03F-11-D_A1